

AKUTEK 50K¹



Realizzato in inox
Inox made



max h.330 mm



max h.310 mm



120°/180°



4,9 kW

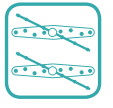
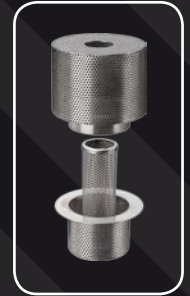

Sistema di lavaggio
Washing system



Controllo carico acqua
Water load control



Porta coibentata
Insulated door



Pannello estraibile
Removable panel



Accessibilità anteriore
Front accessibility



SU TUTTI I MODELLI AKUTEK 50K1

- Circuito risciacquo/lavaggio indipendenti
- Bracci e ugelli inox
- Predisposizione dosatore detersivo con iniettore inox in vasca
- Dosatore brillantante
- Doppio filtro aspirazione inox con raccolta residui solidi
- Scarico vasca filtrato
- Pompa lavaggio autopulente
- "RINSE OK", risciacquo garantito

ALL AKUTEK 50K1 MODELS EQUIPPED WITH

- Rinsing and washing independent loops
- Washing and rinsing arms and nozzles, inox made
- Built-in connection detergent dispenser, inox made
- Rinse aid dispenser
- Double aspiration filter with solid waste collector, inox made
- Tank's drain with filter
- Self cleaning washing pump
- "RINSE OK", assured rinsing

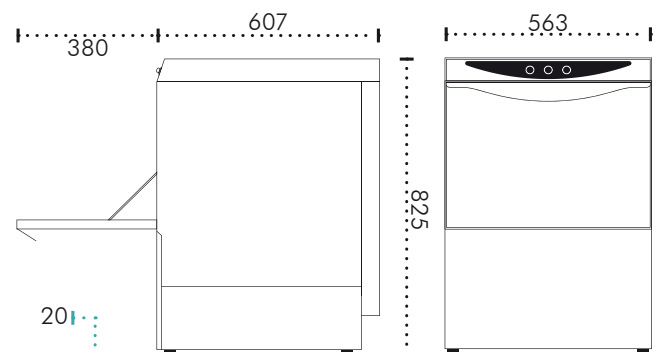

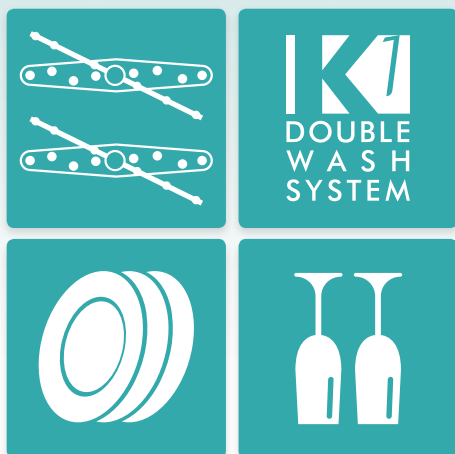

max h.330 mm

max h.310 mm

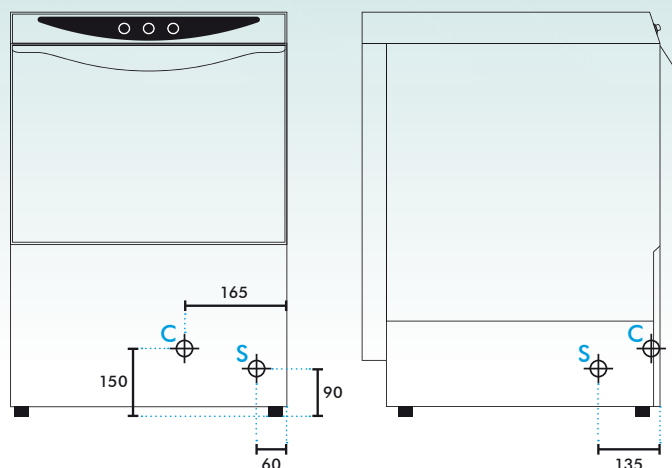

C: attacco tubo di carico

S: attacco tubo di scarico

C: water supply hose attachment

S: water drain hose attachment

DIMENSIONI/Measures

DIMENSIONI CON IMBALLO Packaging measures	700 x 740 x h.970 mm
VOLUME CON IMBALLO Volume with packaging	0,5 mc
PESO NETTO Net weight	47,5 kg
PESO LORDO Gross weight	58,5 kg
LUNGHEZZA TUBO DI CARICO Water supply hose, length	1350 mm
ATTACCO TUBO DI CARICO Water supply hose, attachment	3/4 gas
LUNGHEZZA TUBO DI SCARICO Water drain hose, length	1150 mm
DIAMETRO TUBO DI SCARICO Water drain hose, diameter	1" 3/4 (Ø 24 mm)
ALTEZZA SCARICO DA TERRA Water drain attachment, height from floor	90 mm

IMPIANTO ELETTRICO/Electric system

ALIMENTAZIONE Electrical supply	230V P+N+T/50Hz
	230V 3P+T/50Hz
	400V 3P+N+T/50Hz
ASSORBIMENTO Power consumption	4,9 kW
RESISTENZA BOILER Boiler resistor	4,5 kW
RESISTENZA VASCA Tank resistor	2 kW
POMPA LAVAGGIO Wash pump power consumption	0,4 kW

IMPIANTO IDRAULICO/Hydraulic system

CAPACITÀ VASCA Tank capacity	26 l
CAPACITÀ BOILER Boiler capacity	4,9 l
DUREZZA DELL'ACQUA Water hardness	8 F°
TEMPERATURA MASSIMA ACQUA D'INGRESSO Water input maximum temperature	55 C°
CONSUMO ACQUA PER CICLO Water consumption per cycle	2,8 l

PRODUZIONE/Working output

PRODUZIONE CESTI ORARIA Working racks per hour	30/20
CICLO DI LAVORO Work cycle	120"/180"
MICRO DI SICUREZZA A PORTA Safety door micro switch	✓
LIVELLO ACQUA AUTOMATICO Automatic water level	✓

DOTAZIONE/Equipment

DOTAZIONE CESTI Racks equipment	x2
DIMENSIONI CESTI Racks measures	500 x 500 mm
CONTENITORE POSATE Cutlery case	x1