

# AKUTEK 120



Realizzato in inox  
Inox made



max h.430 mm



max h.405 mm



60"/90"/120"/180"



6,75 kW

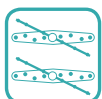

Sistema di lavaggio  
Washing system



Controllo carico acqua  
Water load control



4 tempi di lavaggio  
4 washing cycles



Angoli arrotondati  
Rounded borders



Vasca a scalino  
Wash tank with radial corners

## SU TUTTI I MODELLI AKUTEK 120

- Circuito risciacquo/lavaggio indipendenti
- Bracci e ugelli di lavaggio inox inostruibili
- Bracci e ugelli di risciacquo inox ispezionabili
- Vasca a sedia completamente stampata e priva di saldature
- Predisposizione dosatore detersivo con iniettore inox in vasca
- Filtro inox a tutta vasca con cestello di raccolta
- Pompa di lavaggio totalmente autopulente
- Avviamento ciclo automatico con la chiusura della cappotta
- Dosatore di brillantante
- "RINSE OK" risciacquo garantito

## ALL AKUTEK 120 MODELS EQUIPPED WITH

- Rinsing and washing independent loops
- Obstruction free washing arms, inox made
- Inspectable rinse arms and nozzles, inox made
- Tank with rounded edges, thus ensuring the complete water drainage
- Built-in connection detergent dispenser, inox made
- Inox made filter on the tank's surface with rack to collect solid wastes
- Self cleaning washing pump
- The wash cycle starts automatically when the hood is closed
- Rinse aid dispenser
- "RINSE OK" assured rinsing

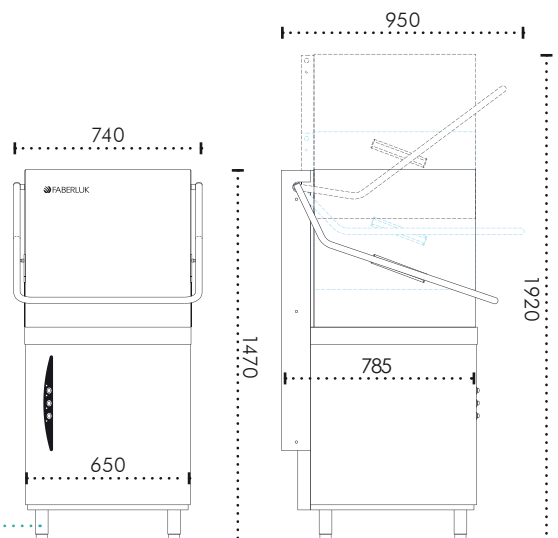

130>190

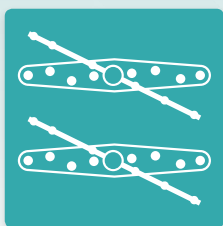

max h.430 mm

max h.405 mm

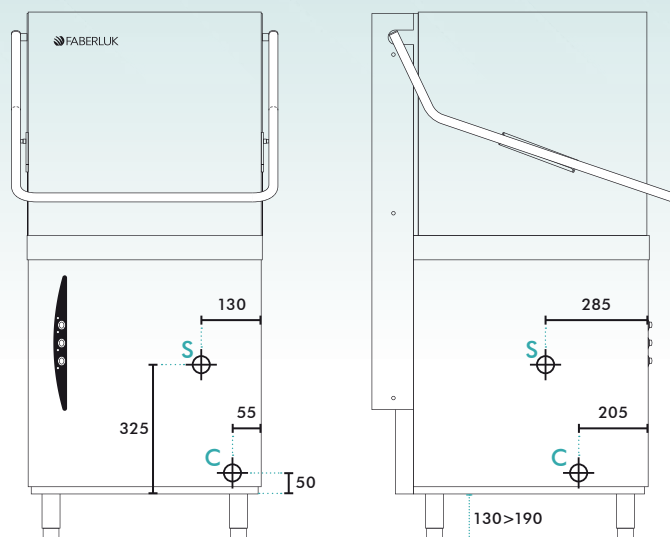

C: attacco tubo di carico  
 S: attacco tubo di scarico  
 C: water supply hose attachment  
 S: water drain hose attachment

## DIMENSIONI/Measures

DIMENSIONI CON IMBALLO Packaging measures	890 x 780 x h.1630 mm
VOLUME CON IMBALLO Volume with packaging	1,1 mc
PESO NETTO Net weight	93,5 kg
PESO LORDO Gross weight	100,5 kg
LUNGHEZZA TUBO DI CARICO Water supply hose, length	1600 mm
ATTACCO TUBO DI CARICO Water supply hose, attachment	3/4 gas
LUNGHEZZA TUBO DI SCARICO Water drain hose, length	1600 mm
DIAMETRO TUBO DI SCARICO Water drain hose, diameter	1" 3/4 (Ø 24 mm)
ALTEZZA SCARICO DA TERRA Water drain attachment, height from floor	455 > 515 mm

## IMPIANTO ELETTRICO/Electric system

ALIMENTAZIONE Electrical supply	230V P+N+T/50Hz
	230V 3P+T/50Hz
	400V 3P+N+T/50Hz
ASSORBIMENTO Power consumption	6,75 kW
RESISTENZA BOILER Boiler resistor	6 kW
RESISTENZA VASCA Tank resistor	3 kW
POMPA LAVAGGIO Wash pump power consumption	0,75 kW

## IMPIANTO IDRAULICO/Hydraulic system

CAPACITÀ VASCA Tank capacity	20,8 l
CAPACITÀ BOILER Boiler capacity	7 l
DUREZZA DELL'ACQUA Water hardness	8 F°
TEMPERATURA MASSIMA ACQUA D'INGRESSO Water input maximum temperature	55 C°
CONSUMO ACQUA PER CICLO Water consumption per cycle	2,8 l

## PRODUZIONE/Working output

PRODUZIONE CESTI ORARIA Working racks per hour	60/40/30/20
CICLO DI LAVORO Work cycle	60"/90"/120"/180"
MICRO DI SICUREZZA A PORTA Safety door micro switch	✓
LIVELLO ACQUA AUTOMATICO Automatic water level	✓
RISCIACQUO SUPPLEMENTARE A FREDDO Additional cold water rinsing	✓

## DOTAZIONE/Equipment

DOTAZIONE CESTI Racks equipment	x2
DIMENSIONI CESTI Racks measures	500 x 500 mm
CONTENITORE POSATE Cutlery case	x1