

# AKUTEK 40B



Realizzato in inox  
Inox made



max h.255 mm



120"



2,97 kW



Sistema di lavaggio  
Washing system



Controllo carico acqua  
Water load control



Porta coibentata  
Insulated door



Pannello estraibile  
Removable panel



Accessibilità anteriore  
Front accessibility



## SU TUTTI I MODELLI AKUTEK 40B

- Vasca a bordi raggiati
- Circuito risciacquo/lavaggio indipendenti
- Bracci e ugelli inox
- Predisposizione dosatore detersivo con iniettore inox in vasca
- Dosatore brillantante
- Doppio filtro aspirazione
- Scarico vasca filtrato
- Pompa lavaggio autopulente
- "RINSE OK", risciacquo garantito
- Risciacquo supplementare a freddo

## ALL AKUTEK 40B MODELS EQUIPPED WITH

- Tank with rounded edges
- Rinsing and washing independent loops
- Arms and nozzles, inox made
- Built-in connection detergent dispenser, inox made
- Rinse aid dispenser
- Double aspiration filter
- Tank's drain with filter
- Self cleaning washing pump
- "RINSE OK", assured rinsing
- Additional cold water rinsing

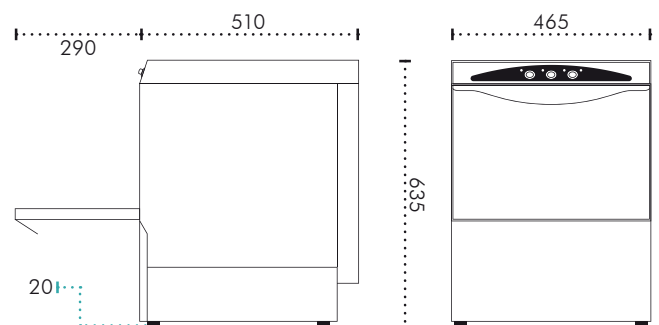

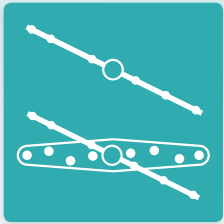

max h.255 mm

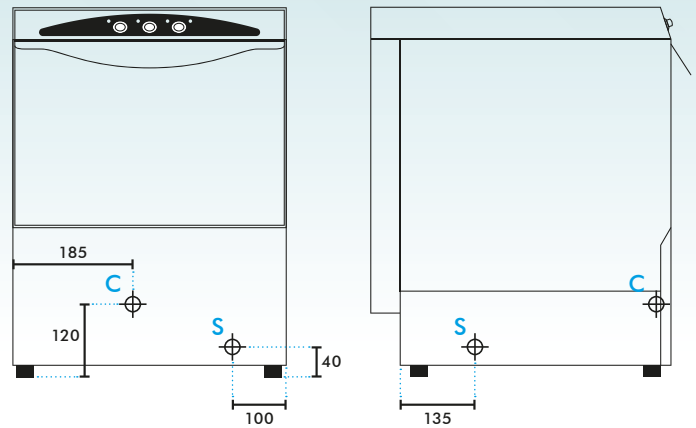

C: attacco tubo di carico

S: attacco tubo di scarico

C: water supply hose attachment

S: water drain hose attachment

## DIMENSIONI/Measures

DIMENSIONI CON IMBALLO Packaging measures	610 x 620 x h.815 mm
VOLUME CON IMBALLO Volume with packaging	0,30 mc
PESO NETTO Net weight	29,5 kg
PESO LORDO Gross weight	37 kg
LUNGHEZZA TUBO DI CARICO Water supply hose, length	1500 mm
ATTACCO TUBO DI CARICO Water supply hose, attachment	3/4 gas
LUNGHEZZA TUBO DI SCARICO Water drain hose, length	1350 mm
DIAMETRO TUBO DI SCARICO Water drain hose, diameter	1" 3/4 (Ø 24 mm)
ALTEZZA SCARICO DA TERRA Water drain attachment, height from floor	40 mm

## IMPIANTO ELETTRICO/Electric system

ALIMENTAZIONE Electrical supply	230V P+N+T/50Hz
ASSORBIMENTO Power consumption	2,97 kW
RESISTENZA BOILER Boiler resistor	2,8 kW
RESISTENZA VASCA Tank resistor	1 kW
POMPA LAVAGGIO Wash pump power consumption	0,17 kW

## IMPIANTO IDRAULICO/Hydraulic system

CAPACITÀ VASCA Tank capacity	14,5 l
CAPACITÀ BOILER Boiler capacity	4 l
DUREZZA DELL'ACQUA Water hardness	8 F°
TEMPERATURA MASSIMA ACQUA D'INGRESSO Water input maximum temperature	55 C°
CONSUMO ACQUA PER CICLO Water consumption per cycle	2,4 l

## PRODUZIONE/Working output

PRODUZIONE CESTI ORARIA Working racks per hour	30
CICLO DI LAVORO Work cycle	120"
MICRO DI SICUREZZA A PORTA Safety door micro switch	✓
LIVELLO ACQUA AUTOMATICO Automatic water level	✓
RISCIACQUO SUPPLEMENTARE A FREDDO Additional cold water rinsing	✓
INDICE DI RUMOROSITÀ Noise output	48 dB

## DOTAZIONE/Equipment

DOTAZIONE CESTI Racks equipment	x2
	Ø 350 mm
	Ø 380 mm
	Ø 400 mm
	400 x 400 mm
CONTENITORE POSATE Cutlery case	x1